

ZTA.50.Mains Track.Framer

STD-000594-0081

Configured Product

Light Source _____

SL98

Light Source Size _____

9mm LES

CCT _____

3000K

Finish _____

Matt Black

Framer type _____

Adjustable Beam

Track adaptor colour _____

Black

Dimming _____

Local Dim

Gobo Holder _____

No

Softening Diffuser/Accessory _____

No

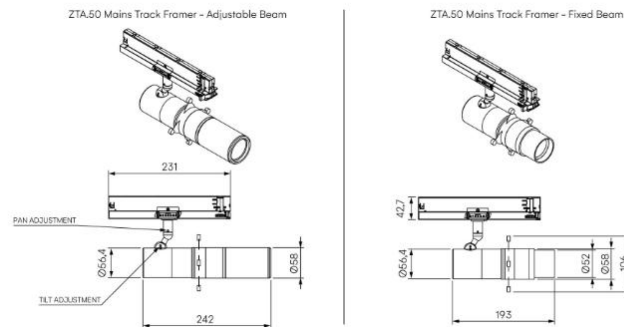

Modular high-performance, mains track-mounted spotlight system, for interior architectural applications such as Museums, Galleries and Retail. Engineered for exceptional durability, maintainability, re-manufacturability, and recyclability, this spotlight sets a new standard for sustainable design.

Product Description

ZTA.50.Mains Track.Framer is constructed from extruded and precision-machined recycled aluminium, the spotlight features an anodised and powder-coated finish for enhanced durability and aesthetics. Easily interchangeable between Framing projector, fixed optic, Wall Wash and Zoom options.

Fixed uses a Wide Flood spread for long throws. Adjustable uses a Zoom lens to allow the user to narrow in on very fine details. Both are capable of holding a gobo.

Key Features

- Sustainable construction: made from recycled aluminium with a long-lasting anodised and powder-coated finish.
- Framing attachment can be easily swapped to fixed optics, Zoom and Wall Wash.
- The easy-to-adjust fins allow for precision positioning to sharply define light on pieces of artwork.
- Versatile Adjustment: 363° pan rotation and 130° tilt with a lockable spot.
- Broad compatibility: 3-circuit adapter supports multiple track systems (Stucchi, Eutrac, Global Pulse).
- Advanced dimming options: On-board, DALI, 0-10V, and Wireless dimming, down to 0.1%.
- High-performance lighting: Up to 98 CRI LEDs with interchangeable optical systems.
- Ceiling mounting only: Designed exclusively for ceiling installations.

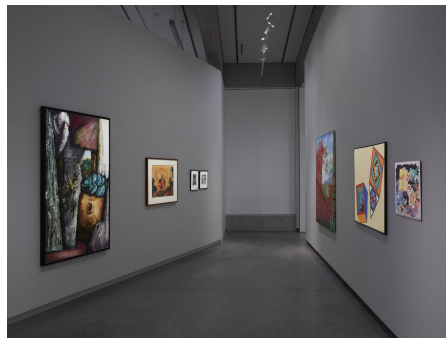

STOANE LIGHTING

EQUIPMENT DESIGN + MANUFACTURE

ZTA.50.Mains Track.Framer

STD-000594-0081

Compliance



Technical

Supply	230V/240V via 3 circuit track
Light source	9mm LES COB
Initial output	SL90 11.8W 33.8Vf at 350mA 2700K · 1822lm · 154lm/W 3000K · 1908lm · 161lm/W 3500K · 1929lm · 163lm/W 4000K · 1919lm · 162lm/W SL98 10.6W 30.4Vf at 350mA 2700K · 1205lm · 113lm/W 3000K · 1288lm · 121lm/W 3500K · 1313lm · 124lm/W 4000K · 1352lm · 127lm/W
Light distribution	Adjustable 10° to 28.9° Fixed 49.3°
Lumen maintenance	L90 B0 in excess of 94,000 hours
Colour consistency	2 SDCM
IP rating	IP20
Weight	1kg

Service Commitment

