

STOANE LIGHTING

EQUIPMENT DESIGN + MANUFACTURE

LI.DL STD-000494-0007

Modular high-performance, recessed fixed downlight, for interior architectural applications such as Museums, Galleries, Retail and Workplace environments. Engineered for exceptional durability, maintainability, re-manufacturability, and recyclability, this downlight sets a new standard for sustainable design.

Product Description

Lowering the impact of manufacturing: revisiting arguably the most ubiquitous luminaire, the downlight.

LI.DL is the result of our mission to better ways to make the best equipment possible whilst doing the least harm. It is recast in our in-house forge from unavoidable workshop offcuts.

Designed with purpose, and first seen at LiGHT24 and featured in the COOLKITLIST 2024, we believe we have created a luminaire that represents a significant step forward in responsible lighting manufacture.

Key Features

- Sustainable construction: made from recycled aluminium with a long-lasting anodised and powder-coated finish. Specialist finishes available on request.
- High-performance lighting: up to 98 CRI LEDs with interchangeable optical systems.
- Customisable accessories: can house up to two lens accessories.
- Advanced dimming options: DALI, 0-10V, DMX and Wireless dimming, down to 0.1%.

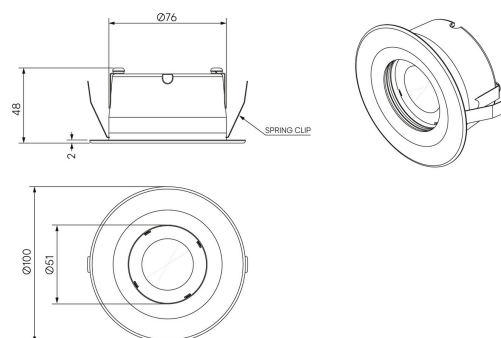

STOANE LIGHTING

EQUIPMENT DESIGN + MANUFACTURE

LI.DL
STD-000494-0007

Configured Product

CCT

2700K

CRI

90

Beam

Flood 35°

Finish

Anodised Clear

Secondary Lensing Accessories

With accessories