

STOANE LIGHTING

EQUIPMENT DESIGN + MANUFACTURE

ZTA.70.Bay STD-000259-0024

Modular high-performance, ceiling mounted spotlight system, for interior architectural applications such as Museums, Galleries, Retail and Workplace environments. Engineered for exceptional durability, maintainability, re-manufacturability, and recyclability, this spotlight sets a new standard for sustainable design.

Product Description

ZTA.70.Bay is constructed from extruded and precision-machined recycled aluminium, the spotlight features an anodised and powder-coated finish for enhanced durability and aesthetics. The spotlight can accommodate up to two lens accessories, making it highly customisable for various lighting needs.

Key Features

- Sustainable Construction: Made from recycled aluminium with a long-lasting anodised and powder-coated finish. Specialist finishes available on request.
- High-Performance Lighting: Up to 98 CRI LEDs with interchangeable optical systems.
- Customisable Accessories: Can house up to two lens accessories and various attachments.
- Advanced dimming options: DALI, 0-10V, DMX and Wireless dimming, down to 0.1%.

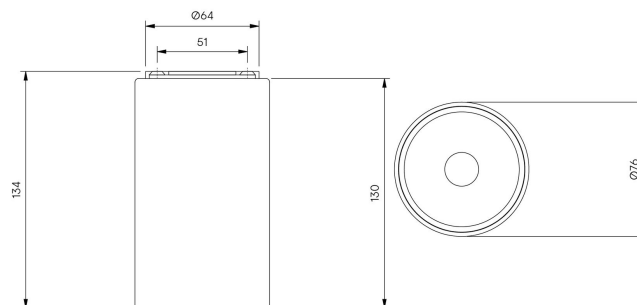

STOANE LIGHTING

EQUIPMENT DESIGN + MANUFACTURE

ZTA.70.Bay STD-000259-0024

Configured Product

Light source

6mm LES

CCT

3000K

CRI

95

Beam

Wide Flood 66°

Supply

Constant Current

Finish

Please contact us for custom finishing requirements

TBC

Dimming

Driver specific

Secondary Lensing Accessories

With accessories