

# STOANE LIGHTING

EQUIPMENT DESIGN + MANUFACTURE

## ZTA.70.Surface STD-000229-0051

Modular high-performance, surface mounted spotlight system, for interior architectural applications such as Museums, Galleries, Retail and Workplace environments. Engineered for exceptional durability, maintainability, re-manufacturability, and recyclability, this spotlight sets a new standard for sustainable design.

### Product Description

ZTA.70.Surface is constructed from extruded and precision-machined recycled aluminium, the spotlight features an anodised and powder-coated finish for enhanced durability and aesthetics. The spotlight can accommodate up to two lens accessories and multiple attachments, making it highly customisable for various lighting needs.

### Key Features

- Sustainable construction: made from recycled aluminium with a long-lasting anodised and powder-coated finish. Specialist finishes available on request.
- Versatile adjustment: 363° pan rotation and 130° tilt with a lockable spot.
- High-performance lighting: Up to 98 CRI LEDs with interchangeable optical systems.
- Customisable accessories: Can house up to two lens accessories and various attachments.
- Advanced dimming options: DALI, 0-10V, DMX and Wireless dimming, down to 0.1%.

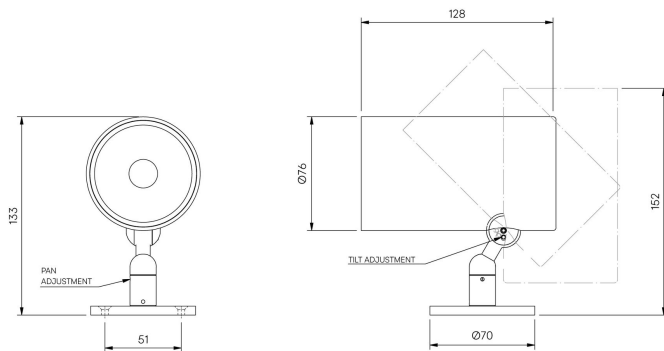

# STOANE LIGHTING

EQUIPMENT DESIGN + MANUFACTURE

## ZTA.70.Surface STD-000229-0051

### Configured Product

Light source

14.5mm LES

CCT

2700K

CRI

95

Beam

Narrow 22°

Supply

Constant Current

Finish

Please contact us for custom finishing requirements.

Custom

Dimming

N/A

Attachments

Straight/Slash Cut Snoot (specified separately)

Cable route

"Flying Lead" is cable exit through rear of lamp tube.

Through Base

Cable Length

500mm

Secondary Lensing Accessories

**STOANE** LIGHTING

EQUIPMENT DESIGN + MANUFACTURE

ZTA.70.Surface  
STD-000229-0051

With accessories