

STOANE LIGHTING

EQUIPMENT DESIGN + MANUFACTURE

ZTA.50.Surface.Zoom STD-000226-0017

Modular high-performance, surface mounted spotlight system, for interior architectural applications such as Museums, Galleries, Retail and Workplace environments. Engineered for exceptional durability, maintainability, re-manufacturability, and recyclability, this spotlight sets a new standard for sustainable design.

Product Description

ZTA.50.Surface Zoom is constructed from extruded and precision-machined recycled aluminium, the spotlight features an anodised and powder-coated finish for enhanced durability and aesthetics. Easily interchangeable between fixed optic, Wall Wash, Zoom and Framing projector options.



Key Features

- Sustainable construction: made from recycled aluminium with a long-lasting anodised and powder-coated finish. Specialist finishes available on request.
- Zoomable beam to allow easy and quick beam adjustment without the need for additional optics.
- Versatile adjustment: 363° pan rotation and 130° tilt with a lockable spot.
- High-performance lighting: up to 98 CRI LEDs with interchangeable optical systems.
- Customisable accessories: can house up to one lens accessory and various attachments.
- Advanced dimming options: DALI, 0-10V, DMX and Wireless dimming, down to 0.1%.

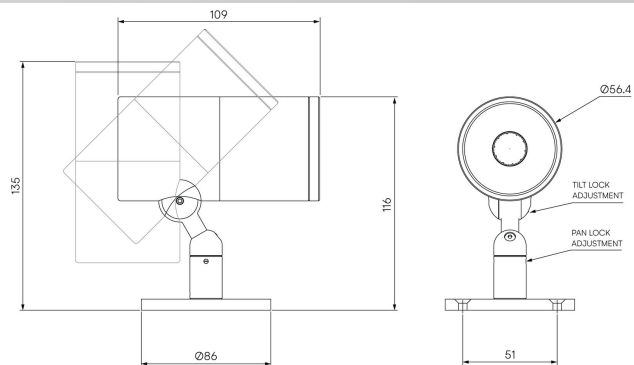

STOANE LIGHTING

EQUIPMENT DESIGN + MANUFACTURE

ZTA.50.Surface.Zoom STD-000226-0017

Configured Product

Light source

Custom

CCT

Custom

CRI

90

Beam

Zoom 13.1° - 59.5°

Supply

Constant Current

Finish

Please contact us for custom finishing requirements.

RAL 9010 Pure White

Dimming

Driver specific

Attachments

None

Cable route

"Flying Lead" is cable exit through rear of lamp tube.

Through Base

Secondary Lensing Accessories

With accessories