

## Fixed Tadpole

STD-000068-0094

### Configured Product

CCT \_\_\_\_\_

2700K

Beam \_\_\_\_\_

Wide Flood 53.7°

Finish \_\_\_\_\_

TBC

Attachments \_\_\_\_\_

Straight/Slash reversible snoot (specified separately)

Secondary Lensing Accessories \_\_\_\_\_

Without accessories

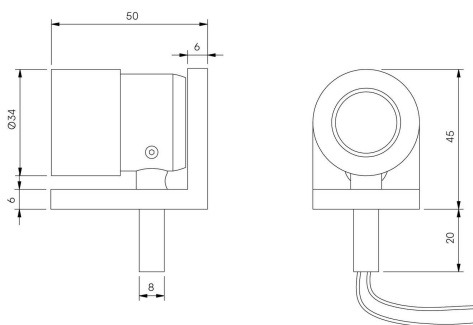

High-performance exterior spotlight system, for wall mounting to illuminate exterior architectural details and landscape illumination.

### Product Description

The Fixed Tadpole is an IP66 exterior rated, fixed focus spotlight. Constructed from precision-machined recycled aluminium, the spotlight features an anodised and powder-coated finish for enhanced durability and aesthetics. Designed to have a crisp clean look whilst offering simple, site-friendly installation. Additional mounting options for spike and surface mount applications.

### Key Features

- Sustainable construction: made from recycled aluminium with a weather resistant long-lasting anodised and powder-coated finish. Specialist finishes available on request.
- Fixed optics can be easily swapped from Very Narrow to Flood to elliptical beam options
- Snoot and Cowl options available.
- Surface and Spike mounted options available.
- Advanced dimming options: DALI, 0-10V, DMX and Wireless dimming, down to 0.1%.
- High-performance lighting: up to 98 CRI LEDs with interchangeable optical systems.

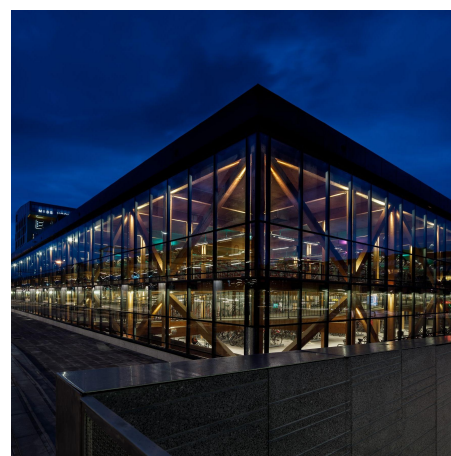
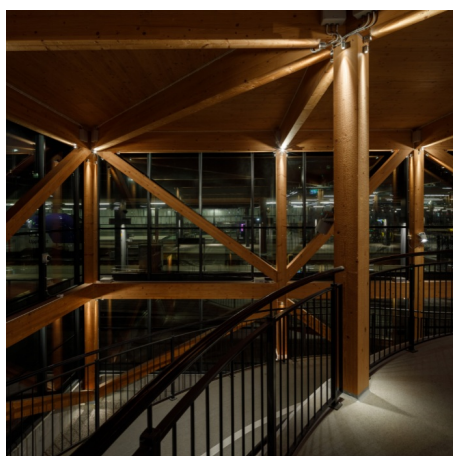

## Compliance



## Technical

Supply	Remote constant current LED driver required
Light source	SL Star
Initial output	95CRI 2W 2.8Vf at 700mA  2700K · 179lm · 90lm/W 3000K · 192lm · 96lm/W 3500K · 204lm · 102lm/W 4000K · 219lm · 110lm/W
Light distribution	Very Narrow 8.5° Narrow 12.4° Medium 21.3° Flood 41.3° Wide Flood 53.7° Elliptical 12.6° x 46.9°
Lumen maintenance	L70 B50 >66,000 hours
Colour consistency	2 SDCM
Colour maintenance	± 0.007 Δu'v'
IP rating	IP66
Weight	0.14kg

## Service Commitment

