



All of our in-house printed paper
is 100% recycled and recyclable

STOANE LIGHTING

EQUIPMENT DESIGN + MANUFACTURE



ZTA.50 Downlight

Installation and Maintenance Instructions

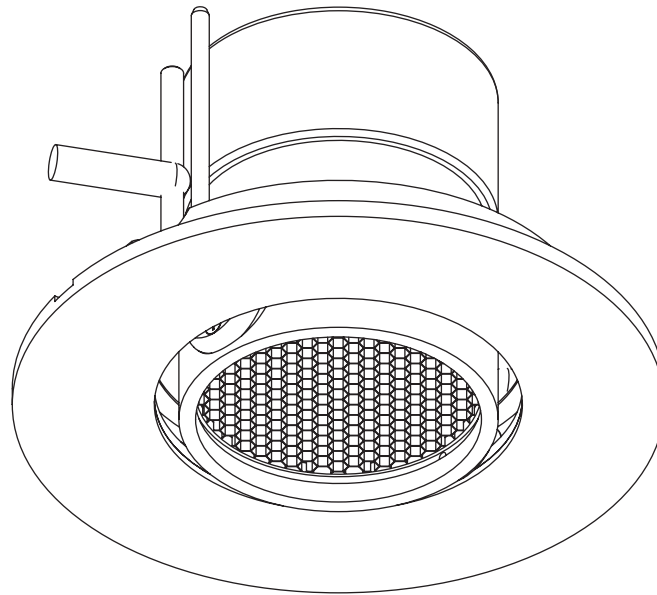

These instructions are for reference only. For product-specific instructions, which may vary, please refer to the documentation supplied with your order.

IMPORTANT: All wiring connections must be made before applying power.



Refer to instructions/product supplied



Do not stare at the operating light source



This product should not be disposed of in your general waste



Please retain these instructions for future reference



Not suitable for covering with thermally insulating material



Class III - Extra Low Voltage

IP20 Indoor Use Only

t_a 35°C Rated maximum ambient temperature



European Conformity



UKCA (UK Conformity Assessed)

Stoane Lighting
20 Dryden Road Bilston Glen Ind Est.
Loanhead Midlothian EH20 9LZ UK

T: +44 (0) 131 440 1313
sales@mikestoanelighting.com

www.stoanelighting.com
VAT No GB682885284
Limited Company 188910

Electrical Supply

Installation must be carried out by a suitably qualified electrician following current building and wiring regulations of the region of installation. Constant current supply from a suitable SELV LED Driver.

Site conditions: LED equipment is more susceptible to static damage and over voltage than previous technology. Before handling or connecting to the mains supply ensure that all Stoane Lighting products are protected from static discharge and that the mains supply is to regulation.

Refer to the fitting label for the module version and total wattage.

Module information;
For module information, including supply current/voltage please refer to the product label or the instructions supplied with your product.

The energy efficiency class of the LED is available in the instructions supplied with your fitting.

Mains cables must be double insulated, strain relieved and separated from E.L.V output cables.

Observe polarity:
Positive (+) is marked as RED.
Negative (-) is marked as BLACK.
Incorrect supply or reverse polarity can cause irreparable damage.

All connections must be made before applying power. If the supply is energised prior to making the connections to the fitting then the resulting surge will damage the LED.

The entire dimming control circuit source must be of SELV insulation class.

Stoane Lighting can provide assistance on dimming compatibility or control systems by request. For advice on specific dimming systems we recommend seeking assistance from the commissioning engineer or the control systems provider in the first instance.

Caution - This product contains magnets. Magnets are dangerous if ingested, can affect pacemakers and other magnetically sensitive equipment.

Ensure the ceiling void ambient temperature does not exceed the fixture's maximum rated ambient temperature (t^a).

Cables must be routed away from hot parts of luminaires especially out of sight in ceiling cavities.

Maintenance:

All lighting equipment is delicate and easily damaged through misuse or inappropriate installation (mechanical or electrical). Repairs and replacements may cause delays and will be chargeable. Contact Stoane Lighting for support if required.

All Stoane Lighting products are covered by a five year Warranty and a 25 year Duty of Care. Products are designed to be upgraded, adapted and refreshed using our comprehensive ReNew service. For more information on our ReNew service and for full Warranty terms and conditions visit stoanelighting.com or contact us at the address shown.

When supplying digital equipment with the potential to be connected to networks, physically or wirelessly (i.e. Bluetooth, WiFi, DMX radio etc.), Stoane Lighting does not take responsibility for the digital security of the equipment or associated networks. It is the customer's responsibility to select a protocol suitably robust for their requirements and to ensure responsible utilisation of passwords.

The light source contained in this luminaire shall only be replaced by the manufacturer, their service agent, or a similar qualified person.

If the external flexible cable or cord of this luminaire is damaged, it shall be exclusively replaced by the manufacturer or his service agent or a similar qualified person in order to avoid a hazard.

Disassembly Information is available on the technical section of our website and is accessed by entering your product serial number. Serial numbers are typically located in an area that is not visible when the fitting is installed.

Cleaning:

Fully isolate the fitting and allow to cool.

Clean the fitting with a slightly damp lint free cloth from a mild solution of soap and water. The fitting must be completely dry before reconnecting power.

Incompatible or abrasive chemicals can damage the fitting, contact Stoane Lighting for advice if required.

Installation

Check that the mounting surface is suitable for the installation of this fitting. **Fitting Weight : 0.5kg.**

Installation must be performed by a qualified person.

A 92mm diameter hole is required for mounting. This fitting is suitable for a ceilings 9-40mm thick. An adaptor can be supplied on request for thinner ceilings.

- Step 1 Make mains connections to SELV LED driver and extra low voltage connections to the fitting.
- Step 2 Insert the fitting into the cut-out.
- Step 3 Tightening the 2 CSK fixings will swing the ceiling tabs out and secure the fitting in place.
- Step 4 Secure the cover plate.

Flexible wiring connected to this luminaire shall be effectively routed or secured to avoid a hazard.

This product is for industrial/professional use only and not intended for use by consumers.

Ensure that the installation of this fitting does not compromise any fire barrier offered by your ceiling. Intumescent downlighter fire hoods should be used to maintain the integrity of the barrier in the event of a fire.

Do not cover the luminaire with insulation. Heat sinks and fan assisted lamps must be kept free from dust and well ventilated to ensure long term reliability and light quality.

WARNING: Do not look at exposed LED lamps in operation. Eye injury can result.

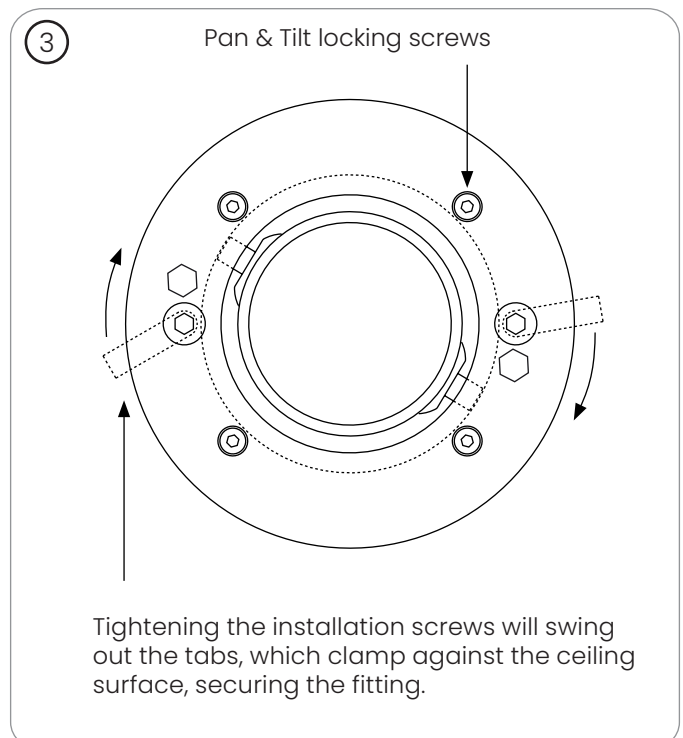
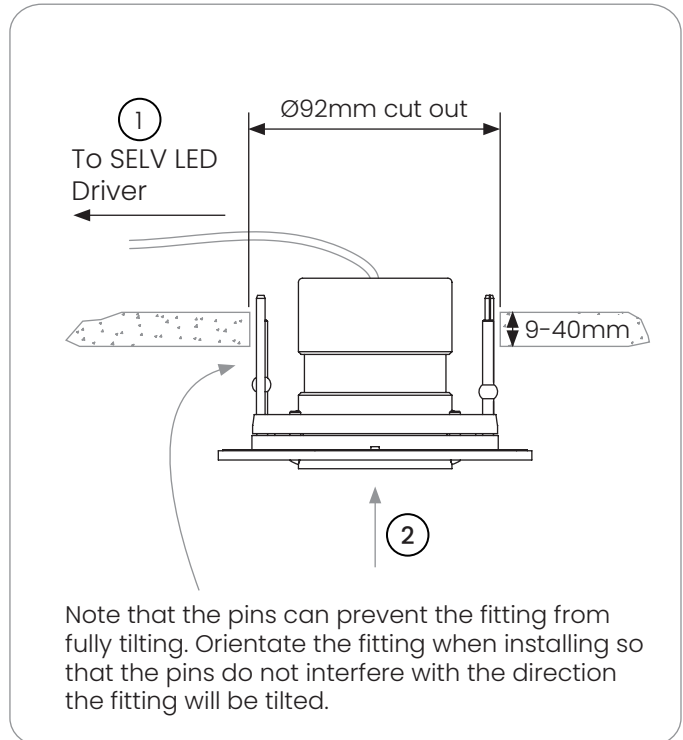

4

To Fit the Cover Plate

Centrally locate the cover plate onto the bezel aligning the slot with the flats on the ADL bezel.

Rotate 90° clockwise to secure.

To Remove the Cover Plate

Rotate 90°

Use a screwdriver or similar in the slot to prise off the plate (Use caution, do not damage the paint)

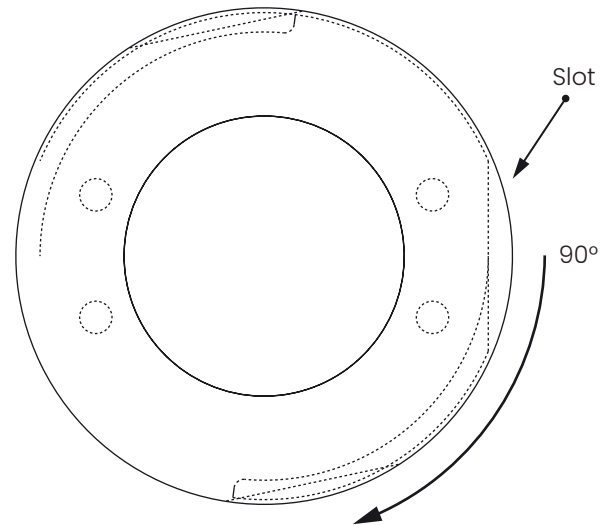
**MODULE AND ACCESSORIES**

The colour temperature and lumen output can be found on the product label on the fitting.

To add/remove accessories:

Isolate the fitting from the supply and allow to cool.

Remove the circlip to access the accessories.
Replace the accessories as required and replace the circlip to secure.

To remove replace optic;

Remove the circlip and accessories to access the optic. Twist the optic anticlockwise to remove from the holder.
Reverse the procedure to replace the optic.

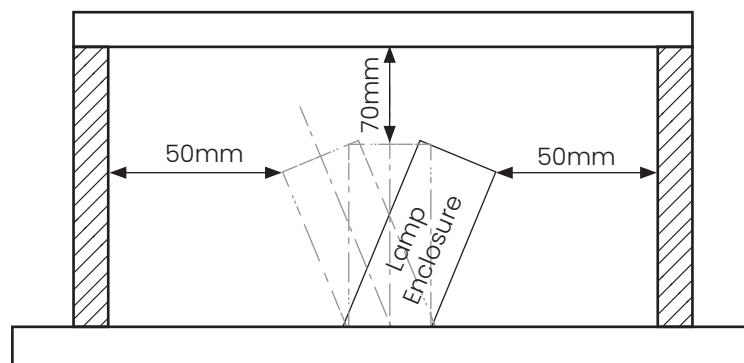
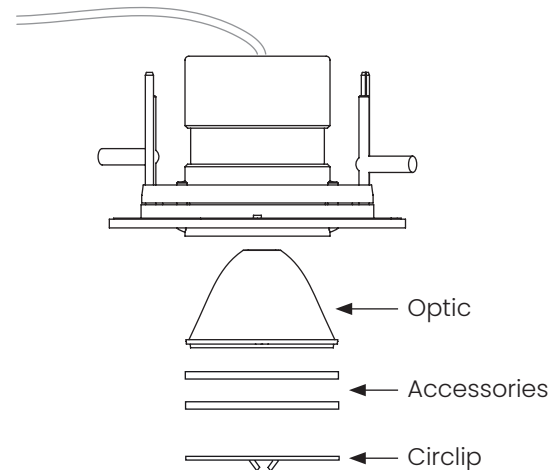

The above image shows the minimum installation dimensions required.

LED Wiring

SUPPLY

Installation must be carried out by a suitably qualified electrician following current building and wiring regulations of the region of installation. Mains supply to a suitable SELV LED Driver.

Mains cables must be double insulated and strain relieved.

Observe polarity:

Positive (+) is marked as RED.

Incorrect supply or reverse polarity can cause irreparable damage.

All connections must be made before switching on mains.

Ensure supply driver and connectors are housed indoors OR in a suitable IP rated enclosure.

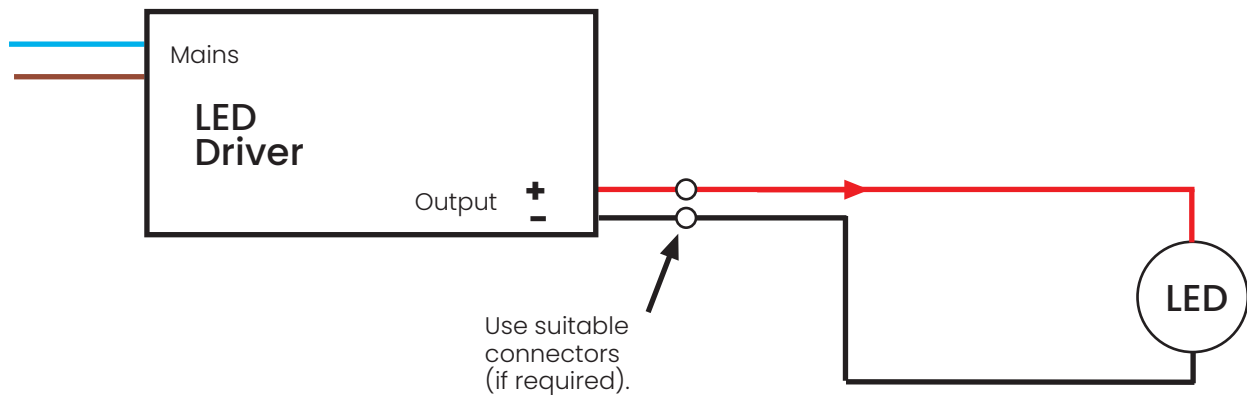

Certified



Stoane Lighting firmly believe that we have a responsibility as environmental custodians, we believe that lighting equipment should be built to last, to be repaired and to be reused. As a BCorp we have pledged to operate a business not aiming to just be best in the world but a business best for the world. Stoane Lighting believe that the circular economy is a fundamental aspect of how we approach the challenges we face. If you read this at the end of the product life we encourage you to consider how you can ensure this product sees an extended life. If removal is unavoidable, please see the disassembly note below.

All Stoane Lighting products are supplied with a 5 year warranty and a 25 year duty of care.



Stoane Lighting operate a ReNew division, which can take your existing fittings and refurbish or upgrade without the need for replacing what you already have.



Through the ReNew service, Stoane Lighting provides general repair, deep cleans and electrical safety checks on luminaires, as well as possible repainting if needed. We will replace components that are nearing end of life, such as drivers, LEDs, and optics. If the fittings are to be used in a new area, or the existing space is undergoing a change in use, ReNew can offer a different mounting method or light technical performance (such as colour tuning), if needed, alongside the addition of on-board wireless control. ReNew as a service, depending on location, can be done on site or by returning equipment to Stoane Lighting.

Once fittings have been repaired or upgraded through ReNew, they will start a new five-year warranty period, and any unwanted parts will be recycled.



Product Disassembly and Component Recycling - While every effort has been made to ensure that our products are built to last and are ReNewable, there may come a point when, as a very last resort, the fittings need to be recycled. The Stoane Lighting website will provide information on how the fitting can easily be disassembled into its component parts for more effective recycling. Information on recycling services in your local region can also be supplied on request.

For more information on the above please visit stoanelighting.com or contact us at the address shown.