



All of our in-house printed paper is 100% recycled and recyclable

STOANE LIGHTING

EQUIPMENT DESIGN + MANUFACTURE



Iris

Installation and Maintenance Instructions

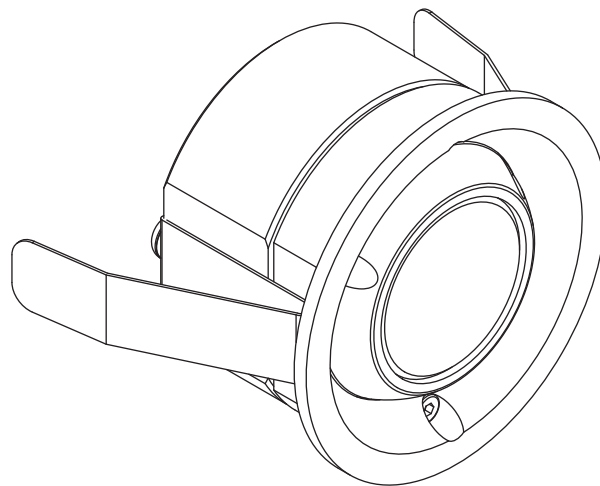

These instructions are for reference only. For product-specific instructions, which may vary, please refer to the documentation supplied with your order.

IMPORTANT: All wiring connections must be made before applying power.



Refer to instructions/product supplied



Do not stare at the operating light source



This product should not be disposed of in your general waste



Please retain these instructions for future reference



Class III - Extra Low Voltage



IP66 Dust tight and protected against powerful jets of water.



35°C Rated maximum ambient temperature



European Conformity



UKCA (UK Conformity Assessed)

Stoane Lighting
20 Dryden Road Bilston Glen Ind Est.
Loanhead Midlothian EH20 9LZ UK

T: +44 (0) 131 440 1313
sales@mikestoanelighting.com

www.stoanelighting.com
VAT No GB682885284
Limited Company 188910

Electrical Supply

Installation must be carried out by a suitably qualified electrician following current building and wiring regulations of the region of installation. Constant current supply from a suitable SELV LED Driver.

Site conditions: LED equipment is more susceptible to static damage and over voltage than previous technology. Before handling or connecting to the mains supply ensure that all Stoane Lighting products are protected from static discharge and that the mains supply is to regulation.

Max exposed surface temperature 41°C at 25°C ambient

Refer to the fitting label for the module version and total wattage.

Module information;

For module information, including supply current/voltage please refer to the product label or the instructions supplied with your product.

The energy efficiency class of the LED is available in the instructions supplied with your fitting.

Mains cables must be double insulated, strain relieved and separated from E.L.V output cables.

Observe polarity:

Positive (+) is marked as RED.

Incorrect supply or reverse polarity can cause irreparable damage.

All connections must be made before applying power. If the supply is energised prior to making the connections to the fitting then the resulting surge will damage the LED.

Multiple LEDs should be wired in series, refer to driver instructions for minimum/maximum load.

The entire dimming control circuit source must be of SELV insulation class.

Stoane Lighting can provide assistance on dimming compatibility or control systems by request. For advice on specific dimming systems we recommend seeking assistance from the commissioning engineer or the control systems provider in the first instance.

Care must be taken when handling any ingress protection seals, glands or "O" rings to ensure they are kept clean, unblemished and replaced exactly in their required location and suitably fastened home.

Maintenance:

All lighting equipment is delicate and easily damaged through misuse or inappropriate installation (mechanical or electrical). Repairs and replacements may cause delays and will be chargeable. Contact Stoane Lighting for support if required.

All Stoane Lighting products are covered by a five year Warranty and a 25 year Duty of Care. Products are designed to be upgraded, adapted and refreshed using our comprehensive ReNew service. For more information on our ReNew service and for full Warranty terms and conditions visit stoanelighting.com or contact us at the address shown.

When supplying digital equipment with the potential to be connected to networks, physically or wirelessly (i.e. Bluetooth, WiFi, DMX radio etc.), Stoane Lighting does not take responsibility for the digital security of the equipment or associated networks. It is the customer's responsibility to select a protocol suitably robust for their requirements and to ensure responsible utilisation of passwords.

The light source contained in this luminaire shall only be replaced by the manufacturer, their service agent, or a similar qualified person.

If the external flexible cable or cord of this luminaire is damaged, it shall be exclusively replaced by the manufacturer or his service agent or a similar qualified person in order to avoid a hazard.

Disassembly Information is available on the technical section of our website and is accessed by entering your product serial number. Serial numbers are typically located in an area that is not visible when the fitting is installed.

Cleaning:

Fully isolate the fitting and allow to cool.

Clean the fitting with a slightly damp lint free cloth from a mild solution of soap and water. The fitting must be completely dry before reconnecting power.

Incompatible or abrasive chemicals can damage the fitting, contact SL for advice if required.

Installation

Check that the mounting surface is suitable for the installation of this fitting. **Fitting Weight : 0.1kg.**

Installation must be performed by a qualified person.

A 44mm diameter cutout is required for mounting.

Step 1 Make mains connections to SELV LED driver and extra low voltage connections to the fitting.

Step 2 Retaining Wings: Hold in the springs and push into the cutout. Once released the springs will hold the fitting in place.

OR

Retaining Ring: Insert fitting into cutout and secure by screwing the retaining ring onto the rear of the fitting.

Step 3 Adjust fitting orientation and tilt as required. To do this loosen the M2 screws using a 1.5mm Allen key. Re-tighten screws once adjustment has been completed.

The IP rating stated is applicable only when the fitting has been installed as per these instructions.

Ensure supply driver and connectors are housed indoors OR in a suitably IP rated enclosure. Cable ends must be suitably waterproofed. Inspect supply cables before installation to ensure there is no damage which will allow water to enter the fitting.

Flexible wiring connected to this luminaire shall be effectively routed or secured to avoid a hazard.

After opening the sealed portion of the luminaire for any reason, Stoane Lighting recommends running the fitting for 15 minutes with the lid open to expel moisture before closing it up. This will prevent condensation on the lens and protect the fitting from corrosion.

This product is for industrial/professional use only and not intended for use by consumers.

Ensure that the installation of this fitting does not compromise any fire barrier offered by your ceiling. Intumescent downlighter fire hoods should be used to maintain the integrity of the barrier in the event of a fire.

Do not cover the luminaire with insulation. Heat sinks and fan assisted lamps must be kept free from dust and well ventilated to ensure long term reliability and light quality.

WARNING: Do not look at exposed LED lamps in operation. Eye injury can result.

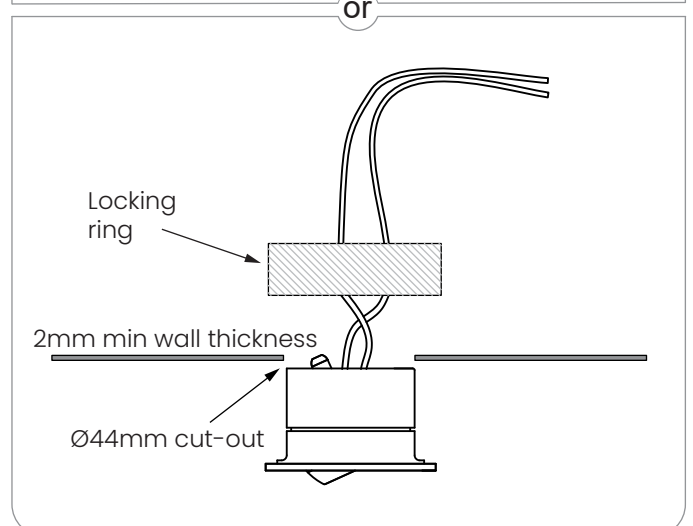
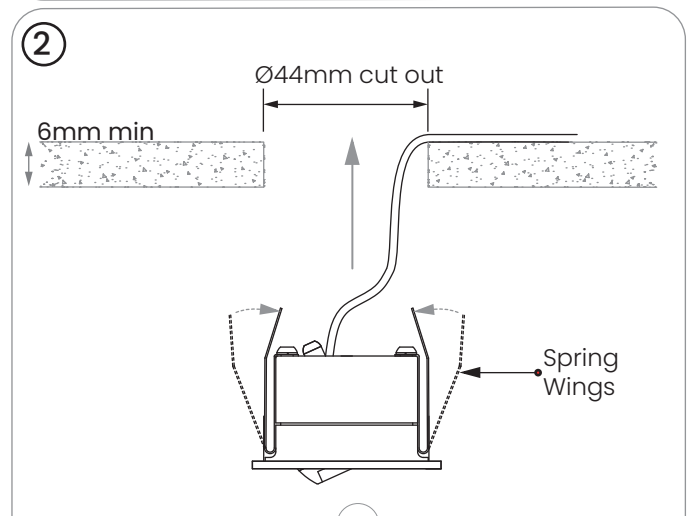
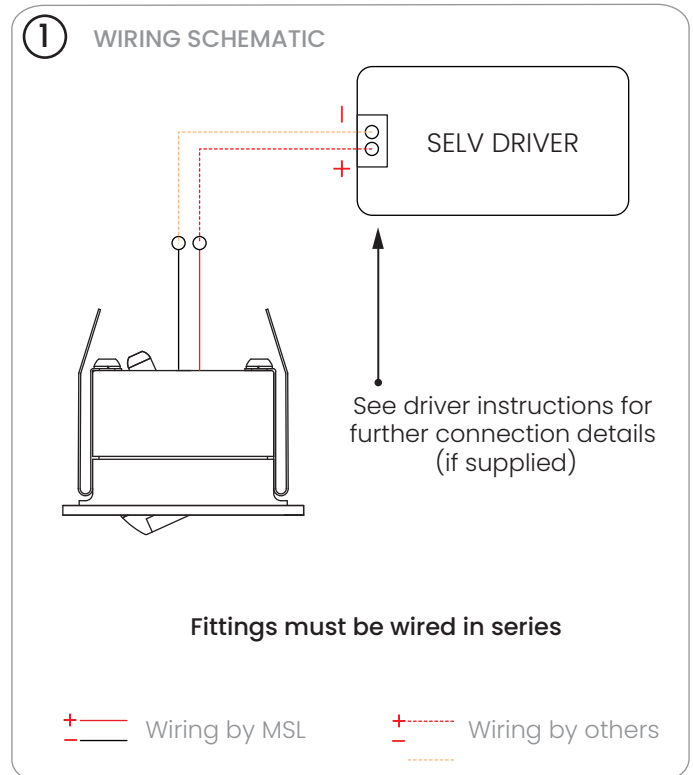

STOANE LIGHTING

EQUIPMENT DESIGN + MANUFACTURE

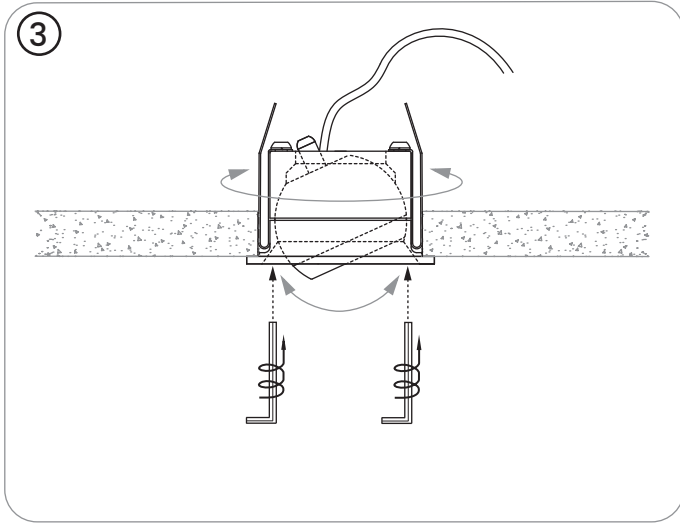

LENS / SNOOT CHANGE

Fully isolate and allow fitting to cool sufficiently before handling. Remove the fitting from the ceiling before changing the lens or snoot.

Step 1 Lock the fitting at a non-tilted position and use the specialist tool provided to unwind the ring anti-clockwise to remove it from the tube.

Step 2 The lens and or snoot can now be removed from the fitting and replaced with one of suitable specification.

Step 3 Reverse process to re-assemble.

Ensure the O-ring sits neatly, is not twisted, stretched or deformed in any way and sits neatly in its groove. It must be free from debris of any kind. If needed, remove the O-ring, clean it and the groove and replace with fresh grease (Loctite Superlube). Failure to do so may result in water ingress and premature failure of the luminaire.

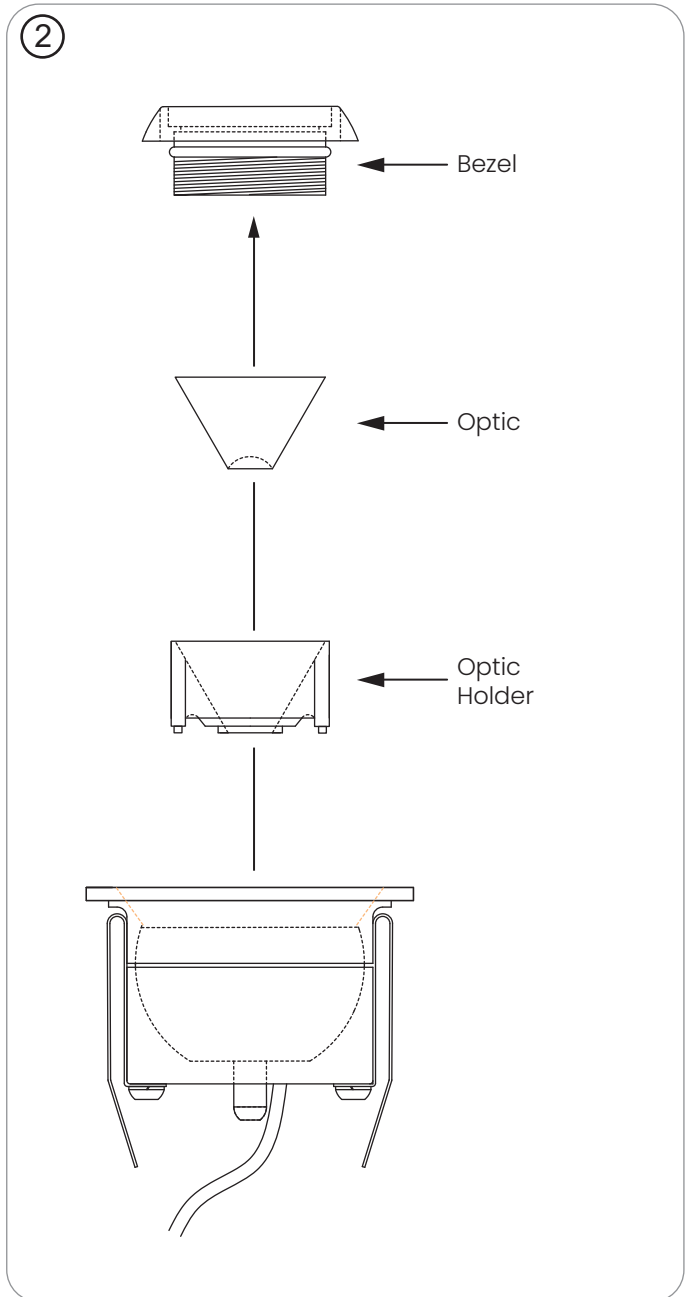
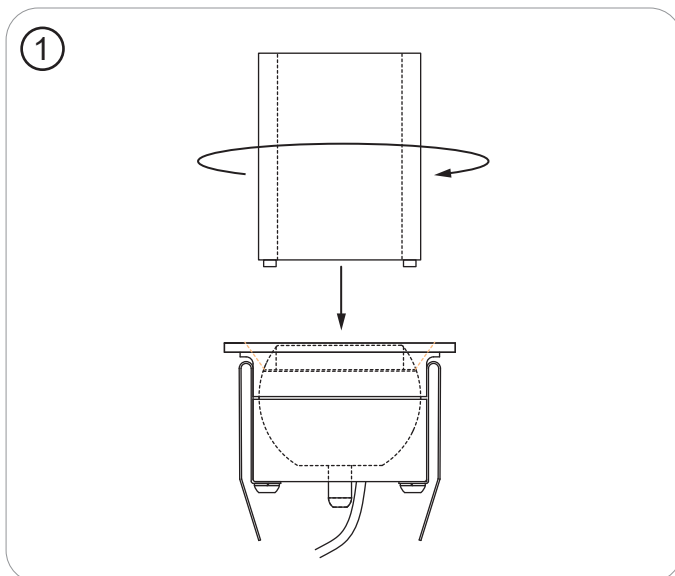
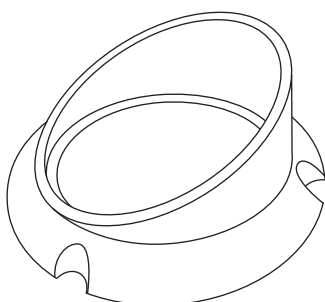
**Snoot options available for additional glare protection**

Slash Cut Snoot

Use the snoot in place of the bezel for additional glare protection.

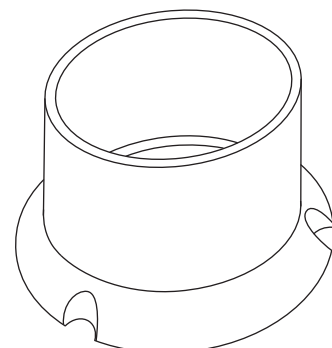

Straight cut snoot

Series Wiring

SUPPLY

Installation must be carried out by a suitably qualified electrician following current building and wiring regulations of the region of installation. Mains supply to a suitable SELV LED Driver.

Mains cables must be double insulated and strain relieved.

Observe polarity:
Positive (+) is marked as RED.
Incorrect supply or reverse polarity can cause irreparable damage.

All connections must be made before switching on mains.

Ensure supply driver and connectors are housed indoors OR in a suitable IP rated enclosure.

Ensure LEDs are connected in 'series' as shown below to the LED drivers.

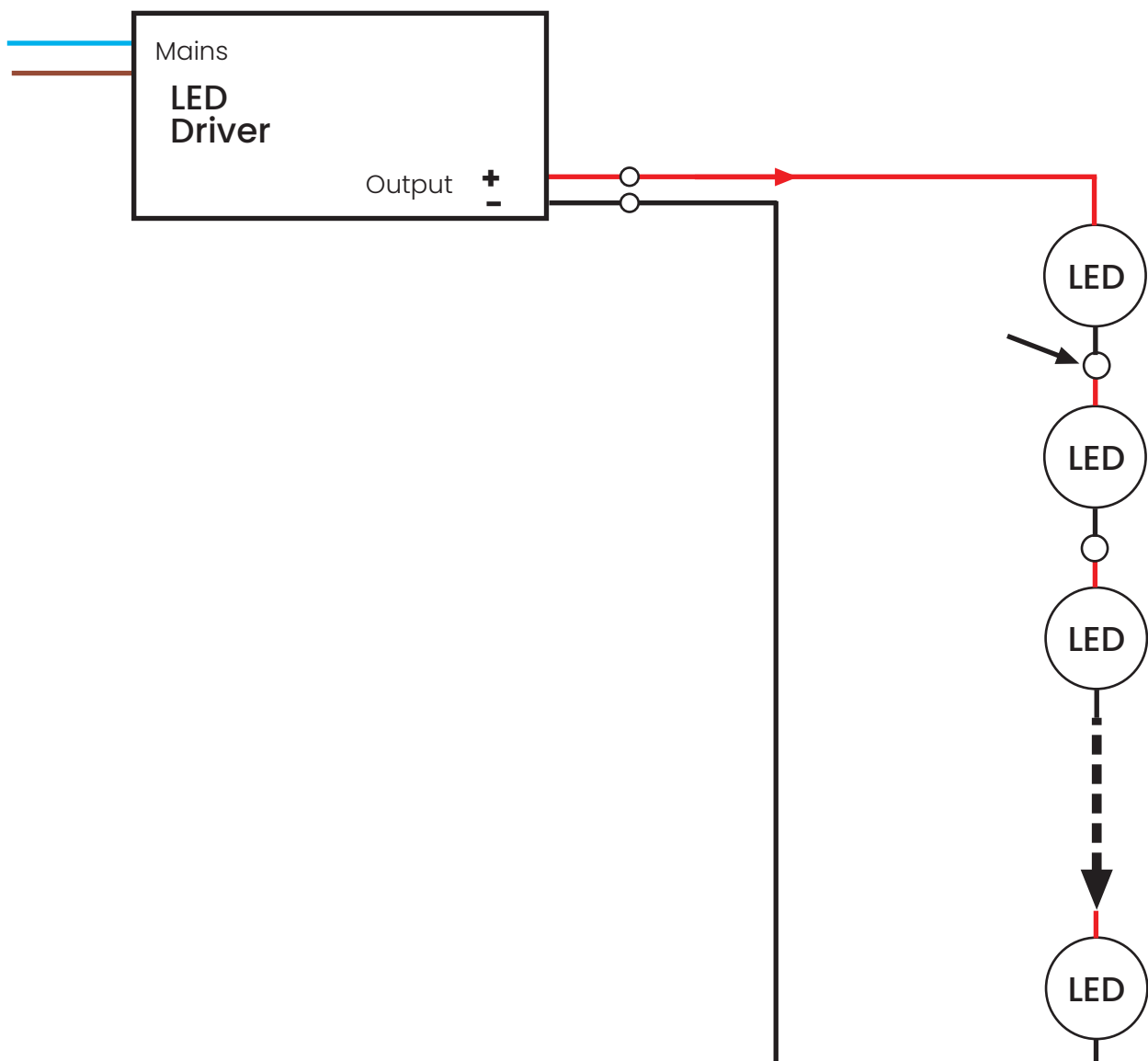

STOANE LIGHTING

EQUIPMENT DESIGN + MANUFACTURE

Certified

Stoane Lighting firmly believe that we have a responsibility as environmental custodians, we believe that lighting equipment should be built to last, to be repaired and to be reused. As a BCorp we have pledged to operate a business not aiming to just be best in the world but a business best for the world. Stoane Lighting believe that the circular economy is a fundamental aspect of how we approach the challenges we face. If you read this at the end of the product life we encourage you to consider how you can ensure this product sees an extended life. If removal is unavoidable, please see the disassembly note below.

All Stoane Lighting products are supplied with a 5 year warranty and a 25 year duty of care.



Stoane Lighting operate a ReNew division, which can take your existing fittings and refurbish or upgrade without the need for replacing what you already have.



Through the ReNew service, Stoane Lighting provides general repair, deep cleans and electrical safety checks on luminaires, as well as possible repainting if needed. We will replace components that are nearing end of life, such as drivers, LEDs, and optics. If the fittings are to be used in a new area, or the existing space is undergoing a change in use, ReNew can offer a different mounting method or light technical performance (such as colour tuning), if needed, alongside the addition of on-board wireless control. ReNew as a service, depending on location, can be done on site or by returning equipment to Stoane Lighting.

Once fittings have been repaired or upgraded through ReNew, they will start a new five-year warranty period, and any unwanted parts will be recycled.



Product Disassembly and Component Recycling - While every effort has been made to ensure that our products are built to last and are ReNewable, there may come a point when, as a very last resort, the fittings need to be recycled. The Stoane Lighting website will provide information on how the fitting can easily be disassembled into its component parts for more effective recycling. Information on recycling services in your local region can also be supplied on request.

For more information on the above please visit stoanelighting.com
or contact us at the address shown.